

# BOLT X

CRANES & RIGS

LONGEST ARM REACH OF OUR HIGH SPEED EQUIPMENT



PAYLOAD  
CAPACITY (KG)



MAXIMUM  
LENS HEIGHT (M)

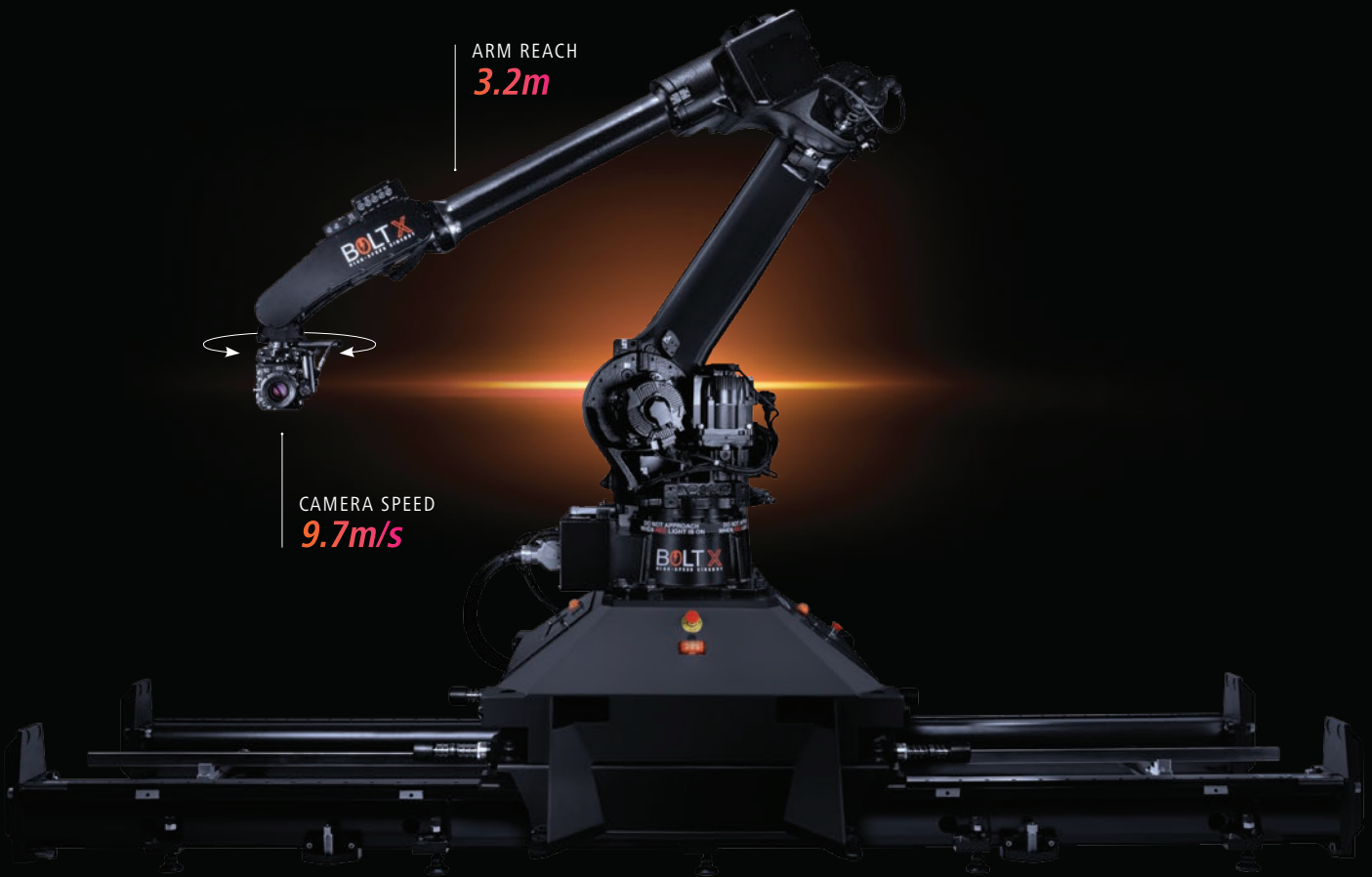

ARM REACH  
**3.2m**

CAMERA SPEED  
**9.7m/s**

The latest edition to our high speed motion control family has the longest arm reach of our high speed equipment. With a reach of 3.2m, the Bolt X allows for greater flexibility in capturing the shots at high speed in the studio and at location settings.



A Nikon Company



MARK ROBERTS MOTION CONTROL

# BOLT X SPECIFICATIONS



## TURNTABLES

Synchronised motion with external triggers and model movers for extreme precision timing.



## PORTABLE

Portable, lightweight robotic unit, designed to be set-up and ready for shooting in under an hour.



## TIMECODE | LIGHTING

Trigger from timecode. Control DMX Lighting.



## TIMELAPSE

Create incredible timelapse with dynamic movement and feel.



## REPEATABLE

Every camera move under complete control – precisely repeatable.



## TARGET TRACKING

Define location of your object in space, to simplify any complex move.



## LENS CONTROL

High speed, precise control of zoom, iris & lens. Fastest & most powerful motors in the world.



## MAYA

Take moves planned in Maya and feed them into the Bolt – or interface to augmented or virtual reality in real-time.

## OPERATING ENVELOPE

<b>Maximum Height</b>	4.3m / 14'1"
<b>Lowest Position</b>	-1.3m / -4'2"
<b>Maximum reach (from rotate centre)</b>	3.2m / 10'6"

## RIG PERFORMANCE

<b>Track</b>	Unlimited range of travel @ 4 m/s
<b>Rotate</b>	+/- 180° range of travel @ 180° /s
<b>Lift</b>	+135 to -90° range of travel @ 180° /s
<b>Arm</b>	+206° to -80° range of travel @ 180° /s
<b>Pan</b>	+/- 200° range of travel at 400° /s
<b>Tilt</b>	+/- 150° range of travel @ 430° /s
<b>Roll</b>	+/- 455° range of travel @ 630° /s

## RIG WEIGHTS & PAYLOAD

<b>Bolt X Rig (Robot Only)</b>	560Kg / 1,235lbs
<b>Pedestal</b>	372Kg / 820lbs
<b>Flair Console Flight Case</b>	36Kg
<b>Counterweights (Pedestal Only)</b>	800Kg per side
<b>Track Weight Plate</b>	200Kg
<b>Maximum Camera Payload</b>	20Kg

## POWER CONNECTION

<b>Power Requirements</b>	415V 3 Phase
---------------------------	--------------

## SHOOTING SPEEDS

<b>Vertical</b>	9.6m/s on arc of radius of 3.1m
<b>Horizontal</b>	9.7m/s on arc of radius of 3.1m

## RIG DIMENSIONS

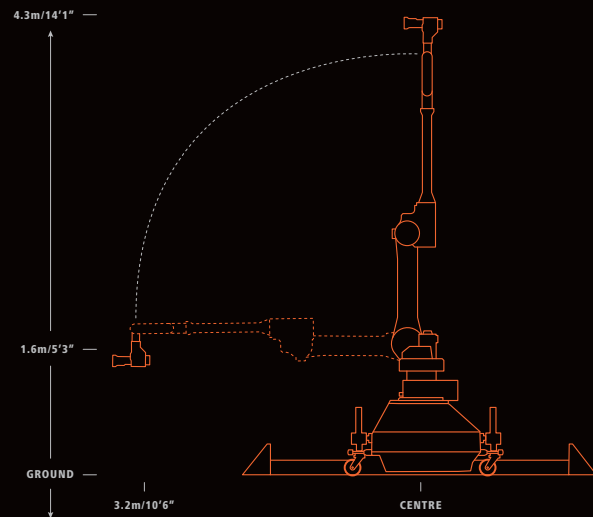

MARK ROBERTS MOTION CONTROL

MARK ROBERTS MOTION CONTROL

TELEPHONE: +44 (0)1342 838000

EMAIL: [info@mrmoco.com](mailto:info@mrmoco.com)

[www.mrmoco.com/boltx](http://www.mrmoco.com/boltx)

A Nikon Company

